

Eclipse RatioAir Burners

Model RA2000

Version 2

Parameter		Specifications
Maximum Input, BTU/hr (kW) ^{1,2}	Chamber Pressure "w.c. (mbar)	Packaged Blower Nominal (60Hz)
	-2.0 (-5,0)	21,475,000 (6392)
	-1.0 (-2,5)	20,950,000 (6138)
	0.0 (0,0)	20,400,000 (5977)
	1.0 (2,5)	19,840,000 (5813)
2.0 (5,0)	19,250,000 (5640)	
Minimum Input, BTU/hr (kW) <i>Lower inputs may be achieved. Contact factory.</i>		350,000 (102)
Main Gas Inlet Pressure, "w.c. (mbar) ³ <i>Fuel pressure at ratio regulator inlet.</i>	Maximum	60 (150)
	Minimum	30 (75)
High Fire Flame Length, inches (mm) <i>Measured from the outlet end of the combustor.</i>		160 (4064)
Maximum Flame Velocity, ft/s (m/s) <i>Approximately 15% excess air at maximum input.</i>		375 (114)
Maximum Application Temperature, °F (°C)	Alloy Combustor	1750 (950)
Flame Detection		UV scanner only
Blower Motor Power, Hp		20" w.c. @ 250,000 scfh, 30 hp
Weight, lbs (kg) ⁵		1069 (485)
Fuel <i>For any other mixed gas, contact Eclipse.</i>		Natural Gas ⁴
Approvals		 AM30

¹ Maximum inputs for packaged blower versions are given for the standard combustion air blower without an inlet air filter.

² Blower motor service factors greater than 1.0 may be required when firing into negative chamber pressure applications. For specific application questions, contact Eclipse.

³ For proper performance, this pressure must be kept constant across the burner operating range.

⁴ See Design Guide 111 for more information about typical fuel composition and properties.

⁵ All weights are approximate.

- All inputs based upon gross calorific values and standard conditions: 1 atmosphere, 70°F (21°C).
- Blower motor service factors greater than 1.0 may be required when firing into negative chamber pressure applications. For specific application questions, contact Eclipse.
- Eclipse reserves the right to change the construction and/or configuration of our products at any time without being obliged to adjust earlier supplies accordingly.
- All information is based on laboratory testing in neutral (0.0" w.c.) chamber with standard combustor design. Different chamber conditions may affect the data.

Control & Operation Zone

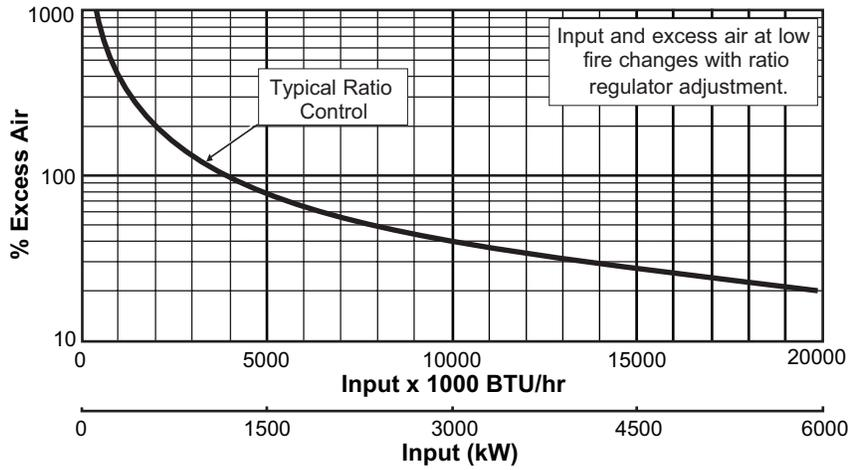

Medium Velocity Combustor Specifications

NO_x Emission Data

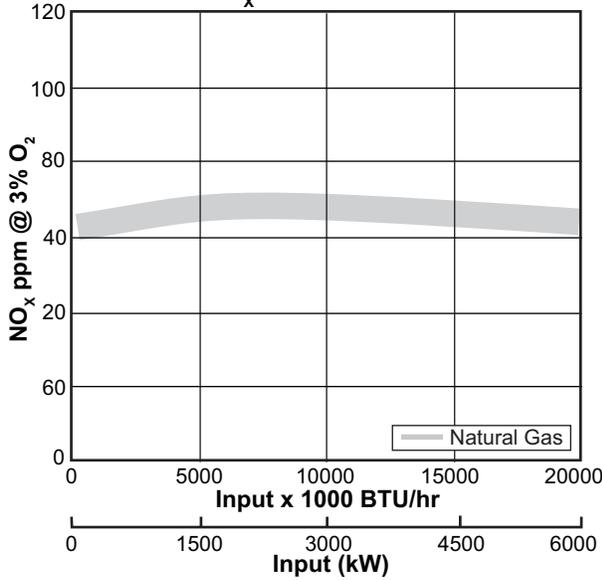

NO_x emission data is given for:

- Ambient combustion air ~70°F (20°C)
- Minimal process air velocity
- ppm volume dry at 3% O₂
- Neutral chamber pressure

Emissions are influenced by:

- Chamber conditions
- Fuel type
- Firing rate
- Ratio regulator adjustment
- Combustion air temperature

CO emission is largely influenced by chamber conditions. Contact your local Eclipse representative for an estimate of CO emission on your application.

Air ΔP vs. Input

(Measured Between Tap C & the Chamber While Firing)

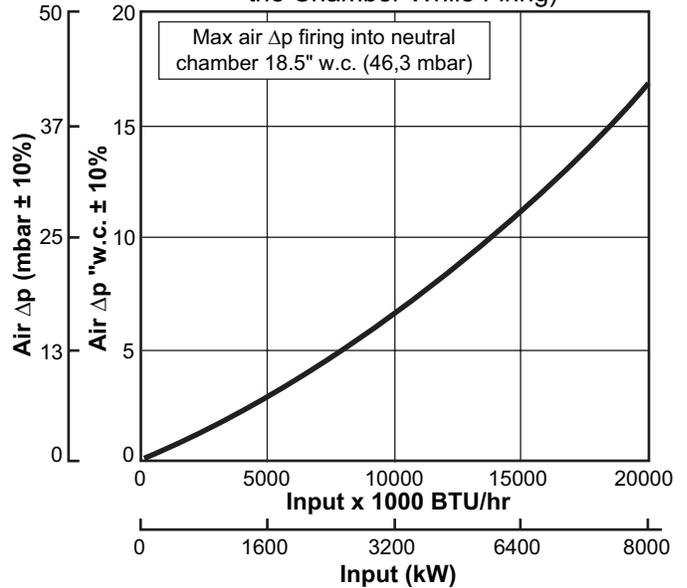

Fuel Orifice Δp vs. Input

Δp Measured Between Taps B & D

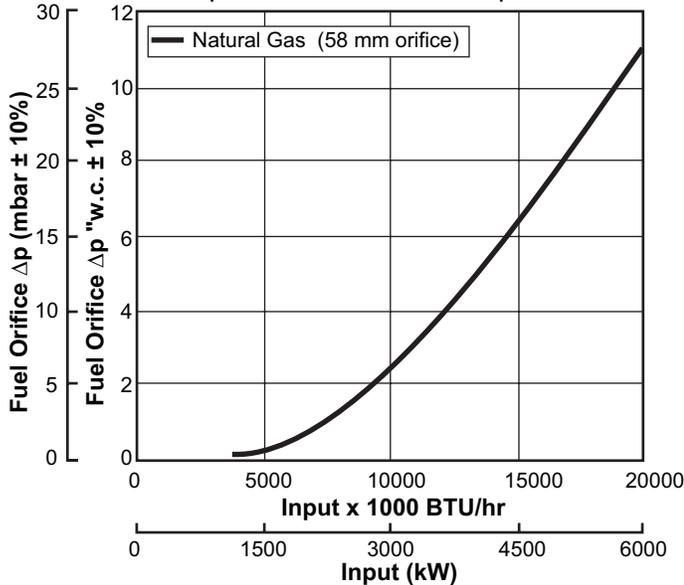

Dimensions in mm (inches)

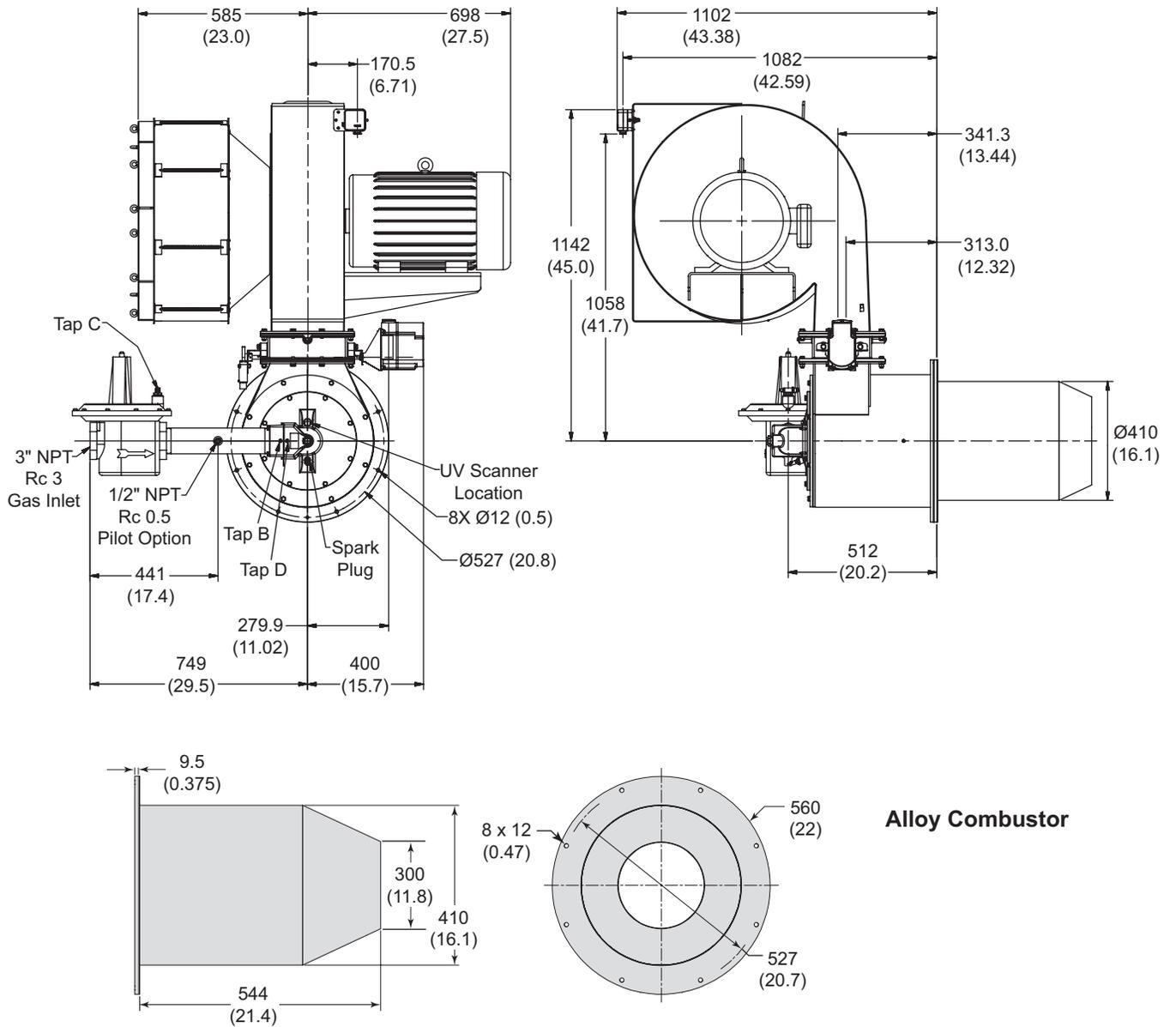

Alloy Combustor



Offered By:

Power Equipment Company
2011 Williamsburg Road
Richmond, Virginia 23231
Phone (804) 236-3800
Fax (804) 236-3882

www.peconet.com